

# Model 300 Winged Sentry

## Model # SS-300-WS

### Product Specifications

#### BASE DIMENSIONS

14.5" Length  
13" Width  
15.5" Height

#### WORK AREA DIMENSIONS

When wings are positioned at 90°  
14" Depth  
28" Width  
13" Height

#### AIR VOLUME

Variable Speed Control Standard on 115V  
350 CFM High, Down to 50 CFM Low  
On/Off Toggle Switch Standard on 220V  
Varies with filter media.

#### WEIGHT

Approx. 40 lbs. - 50 lbs.

#### CABINET MATERIAL

16 ga. Carbon Steel

#### ELECTRICAL

115/1/60, Approx. 0.3 Amps  
220/1/50, Approx. 0.75 amps  
8' grounded power cord with NEMA 5-15P Plug

#### SOUND LEVEL

61 to 66 dba (Blower Speed: Low to High)

#### FILTRATION

Depending on the Application:

- HEPA [up to 99.97% efficient on particles 0.3 microns and larger]
- ASHRAE [up to 95% efficient on particles 0.5 microns and larger]
- ACTIVATED CARBON
- SPECIALTY-BLENDED FILTER MEDIA, [i.e. Acid Gas, Mercury, Aldehyde, Ammonia]

#### WARRANTY

Limited two-year warranty from date of shipment on defects due to materials or workmanship.  
PATENT #5,843,197

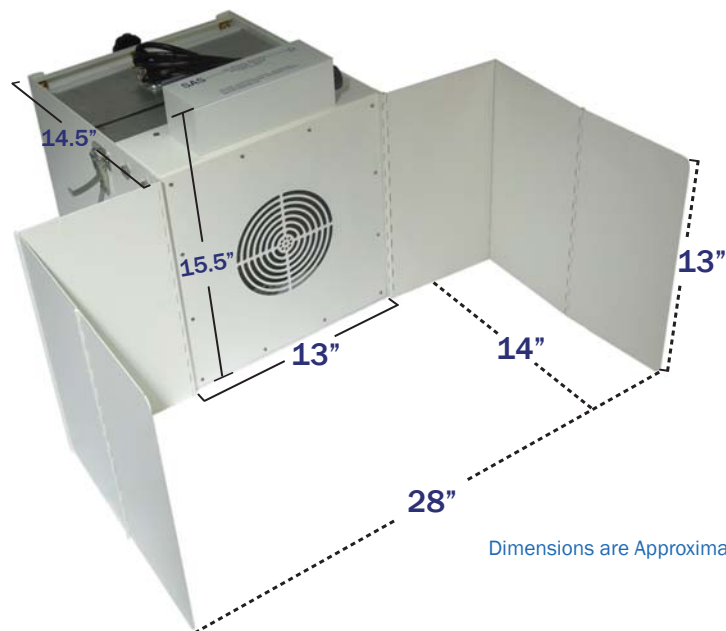

### Product Features

- Variable Speed Controller Included (115V only)
- Simple, Quick "No Tool" Filter Change
- Long Filter Life
- Infinitely Adjustable "Wing Flaps"
- Reliable, Low Maintenance Operation
- Optional Hinged, Clear Acrylic Lid
- Quiet Operation
- Sturdy Construction
- Optional Hour Counter

The **Model 300 Winged Sentry** is a benchtop fume extraction unit that offers a unique design and horizontal airflow pattern. It features infinitely adjustable "wing flaps" to assist in directing contaminated air towards the unit's inlet and into the filter chamber while the operator works between the wings. This system offers hood-like containment without the confinements of working within an actual hood. The operator can place these wings in the most effective position for their application, or they can be placed flat against the sides of the unit to conserve space. This system offers a standard variable speed controller and an optional clear, hinged acrylic lid for those seeking further containment.

Typical applications performed in conjunction with the Winged Sentry are chemical fume extraction, soldering, light grinding, pharmaceutical applications like powder and capsule filling, R&D, solvent and epoxy fume control, and many other applications that involve VOC fumes and dusts.

Appropriate filtration media is selected for the **Winged Sentry** based on the application being performed by the operator. HEPA [up to 99.97% efficient on particles 0.3 microns and larger], ASHRAE [up to 95% efficient on particles 0.5 microns and larger], Activated Carbon, and specialty-blended filter media [i.e. Acid Gas, Mercury, Aldehyde, Ammonia] are the most common options for this unit. The Winged Sentry allows multiple filter media to be housed inside the filter chamber for applications that emit both particulates and fumes. The Winged Sentry is also available in a smaller model [Model SS-200-WS].



1.800.799.4609  
www.sentryair.com  
sales@sentryair.com

